

KK-R

Drag Chain Conveyors

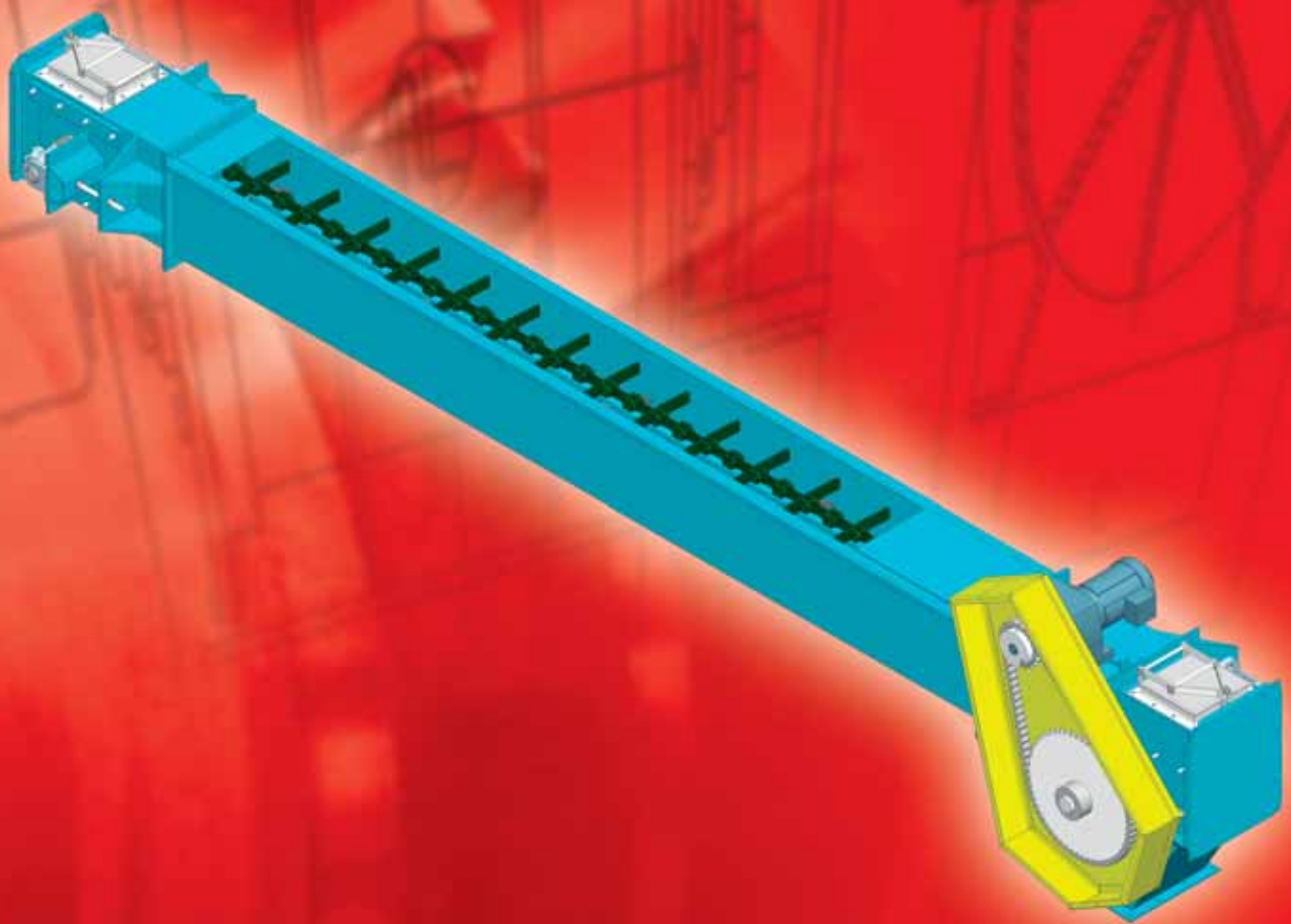

**Laitex Drag Chain Conveyors
are reliable, secure secure in operation,
need of service and maintenance is low.**

— conveying solutions —

KK-R Drag Chain Conveyors

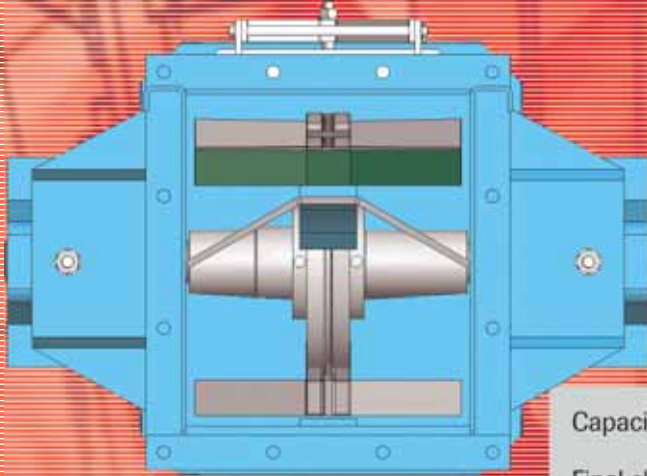
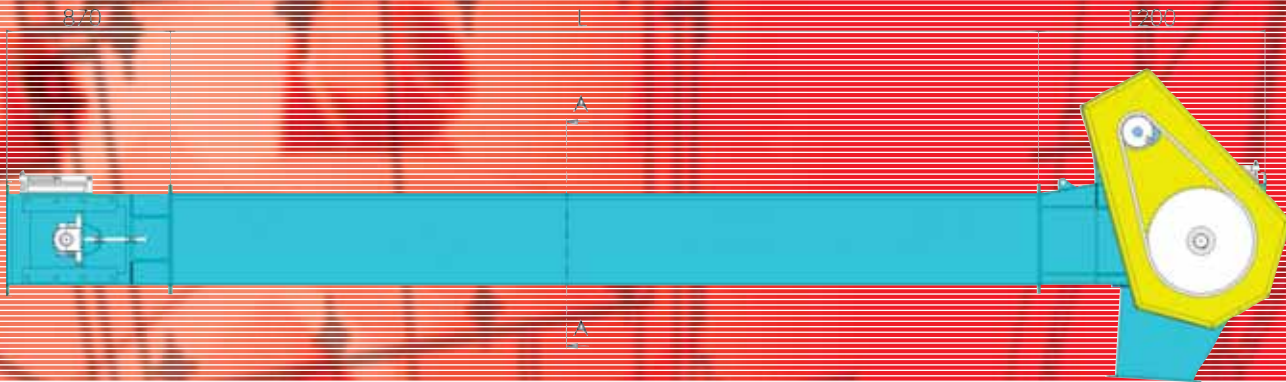

A-A (1:5)

width mm	capacity m ³ /h	chain types(*)
300	20	T142N
400	27	T142N
500	35	T142N
600	40	T142N
700	50	T142N
800	60	2 x T142N
1000	80	2 x T142N
1200	100	2 x T142N

Capacity values are calculated with chain speed 0,1 m/s.

Final chain type is chosen depending on needed chain strength corresponding to speed suitable for the application and material characteristics.

Applications:

Ash handling in power plants (fly - and bottom ash), minerals and industrial minerals, cement and mining industry, etc.

Technical information:

Chain types:	T142N, T142V, 216
Material:	Carbon steel, heat resistant steel, different stainless -and acid-proof steels
Drive unit:	Gear motor with open chain transmission with shear pin or hollowshaft gear motor.
Wear guide:	Wear resistant steel or synthetic resin Stuffing boxes with cords at shaft lead-throughs: stuffing air or crease as option bolted covers Hinged maintenance doors Up-right position bearings
Auxiliaries:	LAITEX SC-10, 0-speed switch Blockage sensor Drive sprocket with changeable tooth rims



LAITEX OY
 Yhteistyökatu 13
 FIN-53300 LAPPEENRANTA
 Tel. + 358 20 161 3300
 Fax. + 358 20 161 3350
 Email: sales@laitex.fi
 Web pages: www.laitex.fi